

CONTENTS

1. LCD MODULE CONTENTS
2. MECHANICAL CHARACTERISTICS
 - 2.1 MECHANICAL DATA
 - 2.2 MECHANICAL DRAWINGS
3. CIRCUIT BLOCK DIAGRAM
 - 3.1 Electrical Block Diagram
 - 3.2 Pins Definition
 - 3.3 Power Supply For LCM Driving
4. ABSOLUTE MAXIMUM RATINGS
 - 4.1 Electrical Absolute Maximum Ratings
 - 4.2 Enviromental Absolute Maximum Ratings
5. ELECTRICAL CHARACTERISTICS
 - 5.1 DC Characteristics
 - 5.2 MPU Interface AC Characteristics
6. BACKLIGHT CHARACTERISTICS
7. ELECTRO-OPTICAL CHARACTERISTIC
8. COMMUNICATION WITH MPU
 - 8.1 Functional Definition
 - 8.2 Display RAM
 - 8.3 Status Read
 - 8.4 Setting Data
9. COMMAND DEFINITION
 - 9.1 Instruction Table
 - 9.2 Explanations Of The Commands
10. CHARACTER GENERATORS
 - 10.1 Character Generator ROM
 - 10.2 Character Generator RAM
11. INSPECTION STANDARDS

2. MECHANICAL CHARACTERISTICS

2.1 MECHANICAL DATA

ITEM	STANDARD VALUE	UNIT
NUMBER OF PIXELS	240(COLUMNS) X 128(ROWS)	
OUTLINE DIMENSIONS	144.0(W) X 104.0(H) X 14.0/10.0(T)	mm
EFFECTTVE VIEWING AREA	114.0(W) X 64.0(H)	mm
DOT SIZE	0.40(W) X 0.40(H)	mm
DOT PITCH	0.45(W) X 0.45(H)	mm
APPROX WEIGHT	150(LED BL VERSION)/120(NO BL)	g

2.2 MECHANICAL DRAWINGS

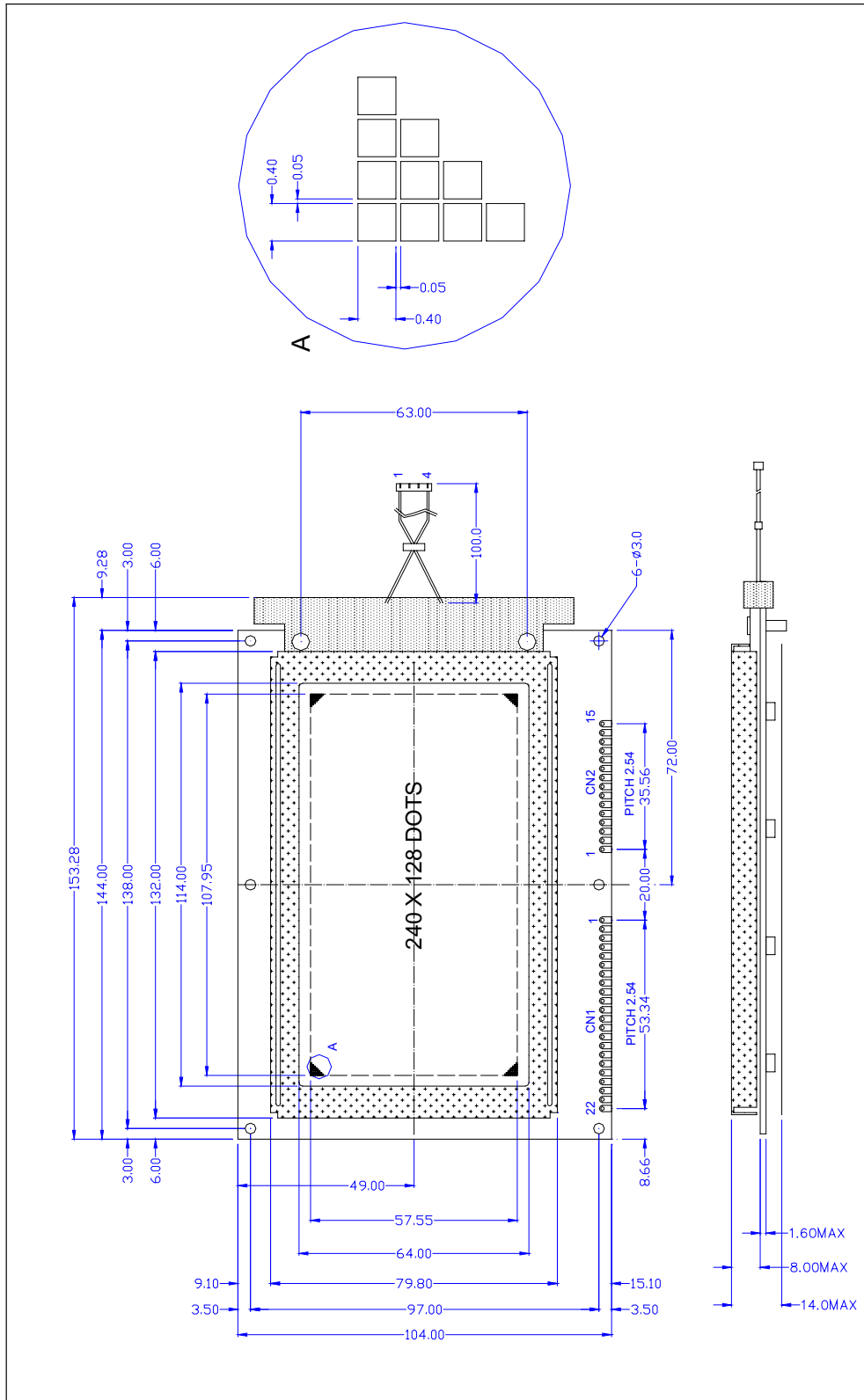

3. CIRCUIT BLOCK DIAGRAM

3.1 Electrical Block Diagram

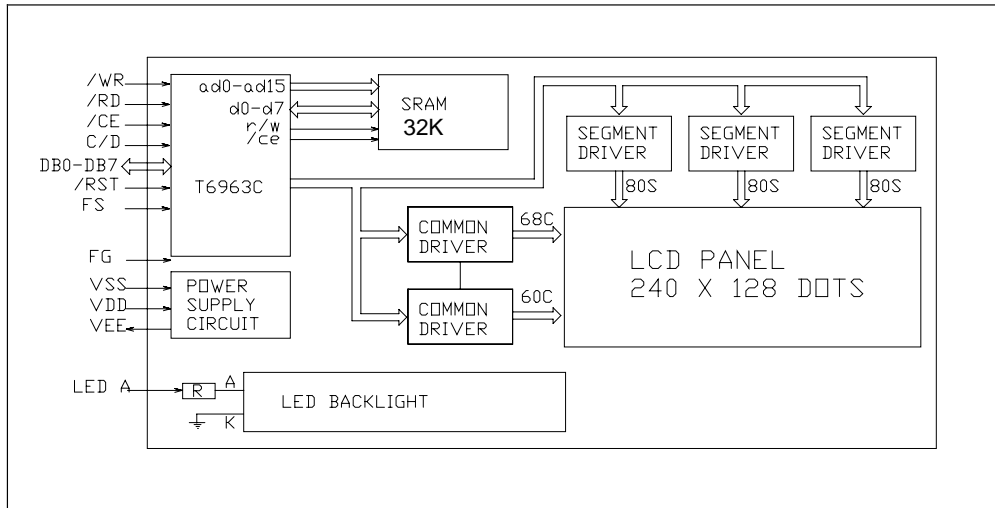

3.2 Pins Definition

CN1: WITH T6963C ON BOARD

PIN	SYMBOL	FUNCTION
1	Vss	Power Supply(GND)
2	Vdd	Power Supply For Logic(+5V)
3	Vo	Power Supply For LCD Driving (Contrast Adjust)
4	C/D	While Write----1: Command Write 0: Data Write While Read----1: Status Read 0:Data Read
5	/RD	Read Signal, Active Low
6	/WR	Write Signal, Active Low
7-14	DB0—DB7	Data Bus
15	/CE	Chip Enable Signal For T6963C, Active Low
16	/RST	Reset Signal, Active Low
17	Vee	Negative Voltage Output/Input(-10V)
18	MD2	Set Number Of The Columns 1:256 Cols; 0:320 Cols
19	FS	Font Select 0: 8X8 Font 1: 6X8 Font
20	NC	No Connection
21	LEDA	Power Supply for LED Backlight (+)
22	LEDK	Power Supply for LED Backlight (-)

3.3 Power Supply For LCM Driving

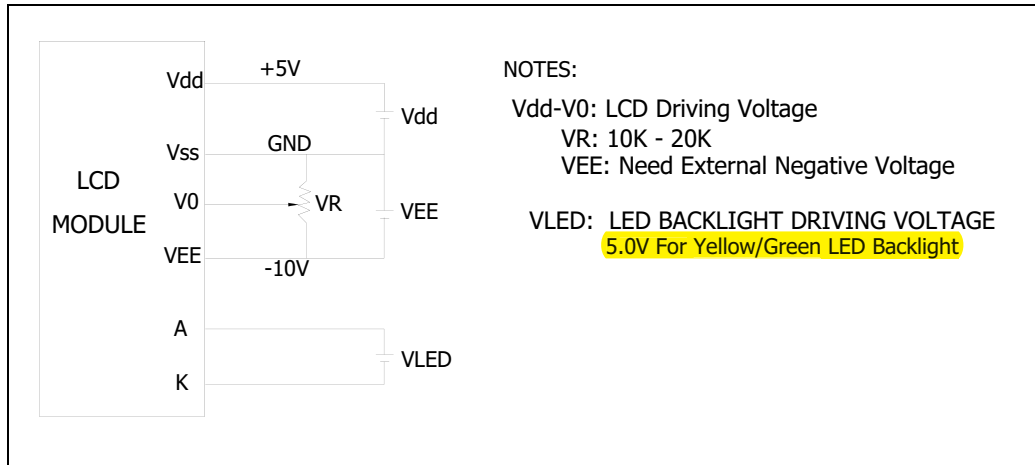

4. ABSOLUTE MAXIMUM RATINGS

4.1 Electrical Absolute Maximum Ratings

ITEM	SYMBOL	CONDITION	MIN	MAX	UNIT
Operating Voltage	Vdd – Vss	-	-0.3	7.0	V
Supply Voltage	Vee-Vss	-	Vdd-30.0	Vdd+0.3	V
Supply Voltage	V0-Vss	-	Vee-0.3	Vdd+0.3	V
Input Voltage	Vi	-	-0.3	Vdd +0.3	V

4.2 Enviromental Absolute Maximum Ratings

ITEM	SYMBOL	CONDITIONS	MIN	MAX	UNIT
Operating Temp	Topr	-Normal temp.	0	50	deg C
Storage Temp	Ttsg	version-	-20	70	deg C
Operating Temp	Topr	Extended temp.	-20	70	deg C
Storage Temp	Ttsg	version	-30	80	deg C
Humidity Endurance	RH	no ondensation Ta<=40 deg	-	95	%
Vibration	-	100-300Hz, X/Y/Z directions, 1 hour	-	4.9m/ss 0.5g	-
Shock	-	10 mS X/Y/Z direction 1 time each	-	29.4m/ss 3.0g	-

5. ELECTRICAL CHARACTERISTICS

5.1 DC Characteristics

Electrical Characteristics at Ta=25 deg C, Vdd = 5V + / - 5%

ITEM	SYMBOL	CONDITION	MIN	TYP	MAX	UNIT
Supply Voltage (logic)	Vdd-Vss	-	4.5	5.0	5.5	V
Supply Voltage (LCD)	Vdd-V0	Vdd = 5V	-	14.5	-	V
Input Signal Voltage	V-ih	"H" level	Vdd-2.2	-	Vdd	V
	V-il	"L" level	0	-	0.8	V
Output Signal Voltage	V-oh	"H" level	Vdd-0.3	-	Vdd	V
	V-ol	"L" level	0	-	0.3	V
Supply Current (logic)	Idd	Vdd=5.0V	-	9.5	-	mA
Supply Current (LCD)	Io	Vdd-V0=14.5V	-	5.0	-	mA

5.2 MPU Interface AC Characteristics

Test Conditions: Ta = -20 to 75°C, Vdd = 5V+/-10%, Vss =0V

ITEM	SYMBOL	MIN	MAX	UNIT
C/D Set-up Time	t _{CDS}	100	-	ns
C/D Hold Time	t _{CDH}	10	-	ns
/CE,/RD,/WR Pulse Width	t _{CE} , t _{RD} , t _{WR}	80	-	ns
Data Set-up Time	t _{DS}	80	-	ns
Data Hold Time	t _{DH}	40	-	ns
Access Time	t _{ACC}	-	150	ns
Output Hold Time	t _{OH}	10	50	ns

BUS TIMING

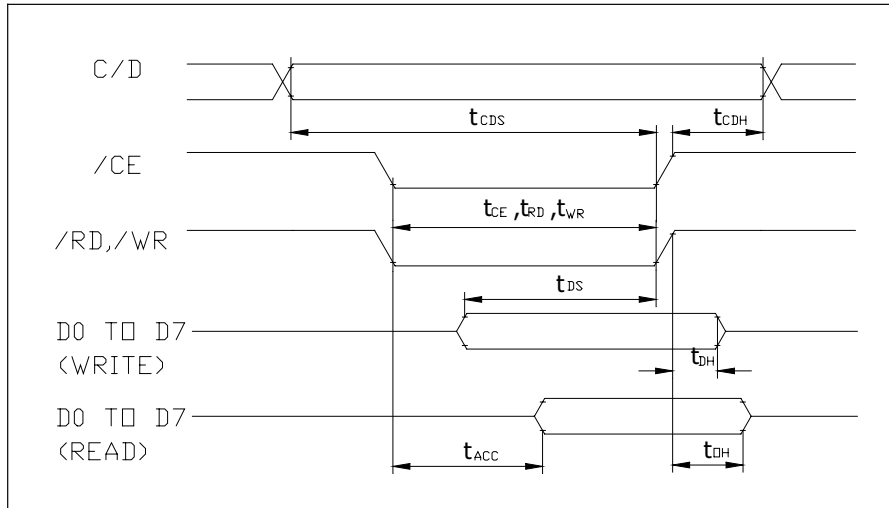

6. BACKLIGHT CHARACTERISTICS

For Side-Lit LED Backlight ($T_a=25^{\circ}C$)

ITEM	SYMBOL	CONDITION	MIN.	TYP.	MAX.	UNIT
LED Voltage	VLED		-	5.0	5.5	V
LED Current	ILED	-	-	180	-	mA
Reverse Voltage	Vr	-	-	-	8	V
Peak Wave Length	λP			Yellow/Green		
Power Dissipation	Pd	-	-	900	-	mW

7. ELECTRO-OPTICAL CHARACTERISTICS

ITEM	SYMBOL	CONDITION	MIN.	TYP.	MAX.	UNIT	REF.
Contrast	CR	25°C	4	--	--		Note1
Rise Time	tr	25°C	--	160	240	ms	Note2
Fall Time	tf	25°C	--	100	150	ms	note 2
Viewing Angle	$\theta 1 - \theta 2$ $\emptyset 1, \emptyset 2$	25°C	-- -40(S)/-15(T)	--	60 40	DEG	Note 3
Frame Frequency	Ff	25°C	--	70	--	Hz	note 2

Note(1): Contrast ratio is defined under the following condition:

$$CR = \frac{\text{brightness of selected condition}}{\text{brightness of non-selected condition}}$$

- (a). Temperature-----25C
- (b). Frame Frequency-----64Hz
- (c). Viewing angle----- $\theta = 0, \emptyset = 0$
- (d). Operating Voltage---5.0V

Note(2): definition of response time:

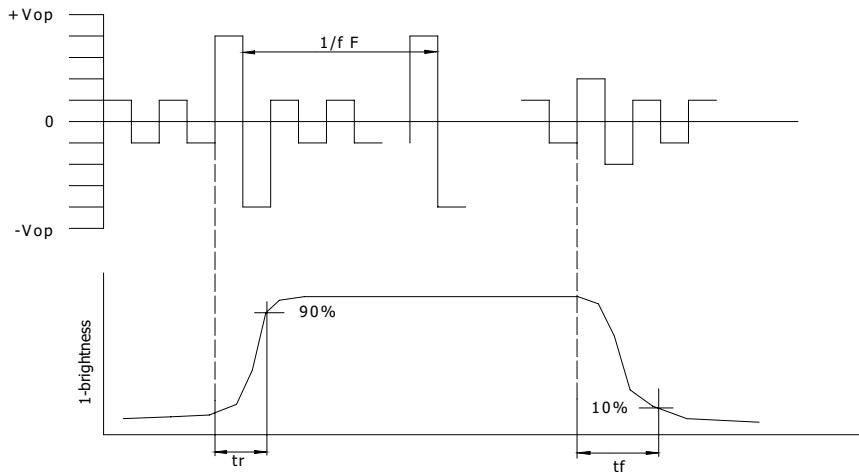

Condition:

- (a). Temperature-----25C
- (b). Frame Frequency-----64Hz
- (c). Viewing angle----- $\theta = 0, \phi = 0$
- (d). Operating Voltage---5.0V

Note(3): definition of view angle:

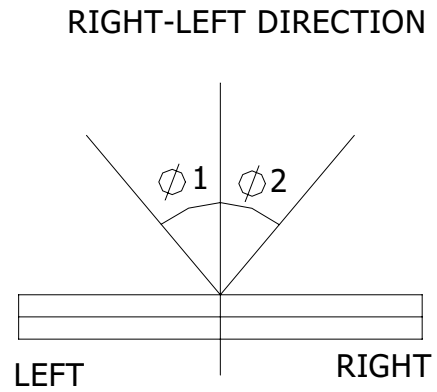
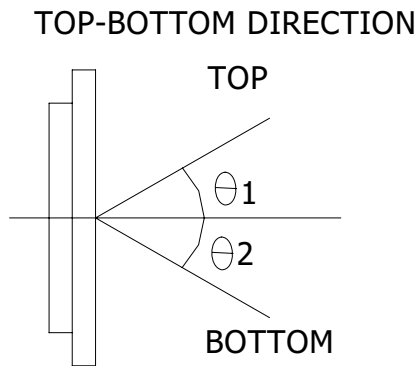

8. COMMUNICATION WITH MPU

8.1 FUNCTIONAL DEFINITION

- After power on, it is necessary to reset. /RST is kept L between 5 clocks up(oscillation clock).
- The column/line counter and display register are cleared by reset.(Other registers are not cleared.) Disable the display using the clear-display register.
- The status must be checked before data or commands are sent. The MSB=0 status check must be done in partucular. There is a possibility of erroneous operation due to a hard interrupt.
- STA0 and STA1 must be checked at the same time. When a command is executed, data transmission errors may occur.
- The T6963C can only handle one byte per machine cycle(16 clocks). It is impossible to send more than two data in a machine cycle.
- When using a command with operation data, it is important to send the data first, and then execute the command
- The character codes used by the T6963C are different from ASCII codes.

8.2 Display RAM

The Display RAM is a 32K bytes SRAM built in the module. It is loceted at address 0000H ~ 7FFFH. All the display data (text, graphic and CG data) is written to this display RAM. T6963C automatically reads the display RAM and sends the data to LCD drivers. The display RAM map is programmable by the "control word set" command. While more than 1 screen data is stored in the RAM, Vertical scrolling and paging is easily performed by resetting text home and/or graphic home address.

8.3 Status Read

The status of the T6963C should be checked between every command and data in order to complete a communication cycle with the MPU. The status can be read from 8 bits data lines (D0 to D7) by setting C/D=H, /RD=L /WR=H and /CE=L.

The format of T6963C status word is as followed:

MSB				LSB			
STA7	STA6	STA5	STA4	STA3	STA2	STA1	STA0
D7	D6	D5	D4	D3	D2	D1	D0

STA0	Check command execution capability	0 : Disable 1 : Enable
STA1	Check data read/write capability	0 : Disable 1 : Enable
STA2	Check Auto mode data read capability	0 : Disable 1 : Enable
STA3	Check Auto mode data write capability	0 : Disable 1 : Enable
STA4	Not used	
STA5	Check controller operation capability	0 : Disable 1 : Enable
STA6	Error flag. Used for Screen Peek end Screen Copy commands.	0 : No error 1 : Error
STA7	Check the blink condition	0 : Display off 1 : Normal display

(Note 1) It is necessary to check STA0 end STA1 at the same time.

(Note 2) For most modes STA0/STA1 are used as a status check.

(Note 3) STA2 and STA3 are used in auto mode.

Status Checking Flow

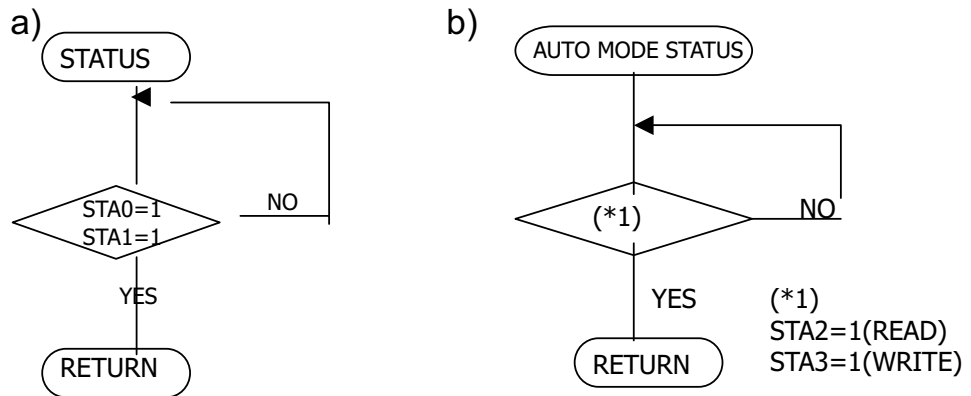

When using MSB=0 command, a Status Read must be performed. If a status check is not carried out, T6963C can't operate normally, even after a delay time. The hardware interrupt occurs during the address calculation period (at the end of each line). If a MSB=0 command is sent to the T6963C during this period, the T6963C enters wait status. If a status check is not carried out in this state before the next command is sent, there is the possibility that the command or data will not be received.

8.4 Setting Data

When using T6963C, first set the data, then set the command.

The procedure of sending a command is as followed:

A) The case of 1 data

B) The case of 2 data

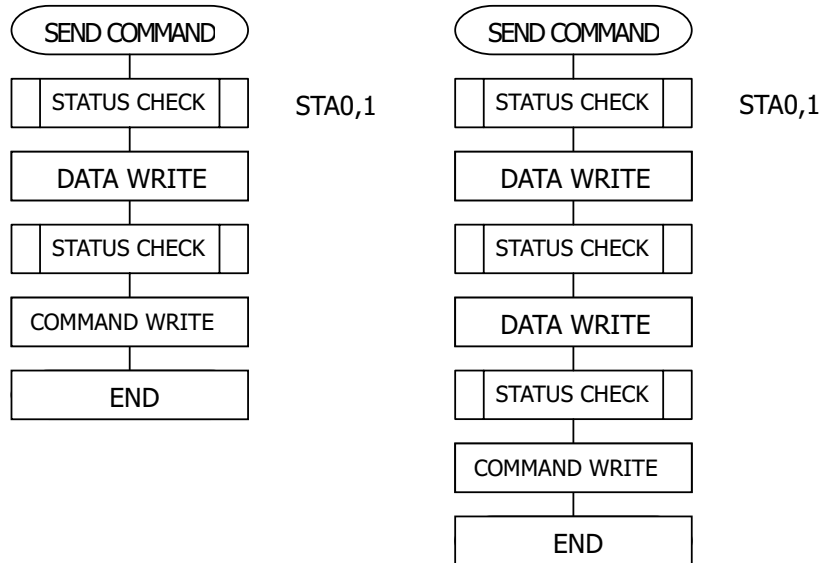

(Note) When sending more than two data, the last datum (or last two data) is valid

9. COMMAND DEFINITIONS**9.1 INSTRUCTION TABLE**

COMMAND	CODE	D1	D2	FUNCTION
REGISTERS SETTING	00100001	X address	Y address	Set cursor pointer
	00100010	Data	00H	Set offset register
	00100100	Low address	High address	Set address pointer
SET CONTROL WORD	01000000	Low address	High address	Set text home address
	01000001	Columns	00H	Set text area
	01000010	Low address	high address	Set graphic home address
	01000011	columns	00H	Set graphic area
MODE SET	1000X000	-	-	OR mode
	1000X001	-	-	EXOR mode
	1000X011	-	-	AND mode
	1000X100	-	-	Text attribute mode
	10000XXX	-	-	Internal CG ROM mode
	10001XXX	--	-	External CG RAM mode
DISPLAY MODE	10010000	-	-	Display off
	1001XX10	-	-	Cursor on, blink off
	1001XX11	-	-	Cursor on, blink on
	100101XX	-	-	Text on, graphic off
	100110XX	-	-	Text off,graphic on
	100111XX	-	-	Text on, graphic on
CURSOR PATTERN SELECT	10100000	-	-	1-line cursor
	10100001	-	-	2-line cursor
	10100010	-	-	3-line cursor
	10100011	-	-	4-line cursor
	10100100	-	-	5-line cursor
	10100101	-	-	6-line cursor
	10100110	-	-	7-line cursor
	10100111	-	-	8-line cursor
DATA AUTO READ/WRITE	10110000	-	-	Set data auto write
	10110001	-	-	Set data auto read
	10110010	-	-	Auto reset
DATA READ/WRITE	11000000	Data	-	Data write and increment ADP
	11000001	-	-	Data read and increment ADP
	11000010	Data	-	Data write and decrement ADP
	11000011	-	-	Data read and decrement ADP
	11000100	Data	-	Data write and nonvariable ADP
	11000101	-	-	Data read and nonvariable ADP
SCREEN PEEK	11100000	-	-	Screen peek
SCREEN COPY	11101000	-	-	Screen copy
BIT SET/RESET	11110XXX	-	-	Bit reset
	11111XXX	-	-	Bit set
	1111X000	-	-	Bit 0 (LSB)
	1111X001	-	-	Bit1
	1111X010	-	-	Bt2
	1111X011	-	-	Bit3
	1111X100	-	-	Bit4
	1111X101	-	-	Bit5
	1111X110	-	-	Bit6
	1111X111	-	-	Bit7 (MSB)

9.2 EXPLANATIONS OF THE COMMANDS

9.2.1. Set registers

CODE	HEX	FUNCTION	D1	D1
00100001	21H	Set cursor pointer	X ADRS	Y ADRS
00100010	22H	Set offset register	DATA	00H
00100100	24H	Set address pointer	LOW ADRS	HIGH ADRS

A) Set cursor pointer

The position of the cursor is specified by X ADRS and Y ADRS. The cursor position can only be moved by this command. Data read/write from the MPU never changes the cursor pointer. X ADRS: 00H to 4FH(lower 7 bits are valid) Y ADRS: 00H to 1FH(lower 5 bits are valid).

B) Set offset register

The offset register is used to determine the external character generator RAM area. The upper 5 bits in start address of CG area is set as the lower 5 bits of D1. And the upper 3 bits of D1 are neglected. D2 should be 00H. Refer to section 10 "Character Generator" for details of the CG RAM.

C) Set address pointer

The Set Address Pointer command is used to indicate the start address for write/read data to/from the built-in RAM.

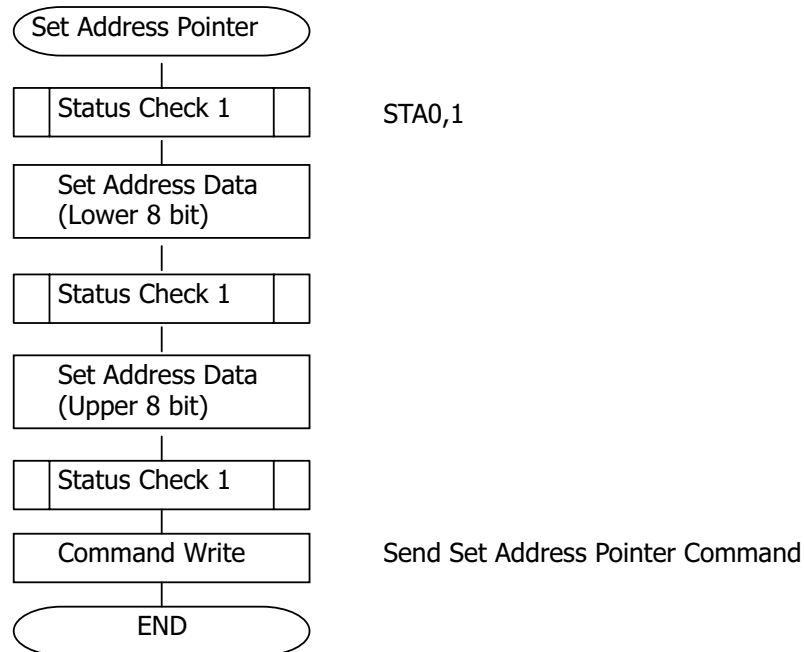

9.2.2. Set Control Word

CODE	HEX	FUNCTION	D1	D2
00100000	40H	Set text home address	Low address	High address
00100001	41H	Set text area	Columns	00H
00100010	42H	Set graphic home address	Low address	High address
00100011	43H	Set graphic area	Columns	00H

A) Set Text Home Address(TH)

This command defines the starting address of display RAM for text display. The data in the text home address(TH) is displayed at the home position of display(left and character on 1st row.

B) Set Text Area(TA)

This command defines the number of columns by D1. Text area can be defined independently from the number of characters fixed by hardware setting of controller LSI. The text area is usually defined as the actual number of characters on LCD display, so addressing can be continuous in the text area.

The relationship between display RAM address and display position(text display)

1) for 8X8 font: TA=1EH, 30 characters per row

TH	---	TH+1DH
TH+TA	---	TH+TA+1DH
TH+2TA	---	TH+2TA+1DH
---	---	---
TH+15TA	---	TH+15TA+1DH

2) for 6X8 font: TA=28H, 40 characters per row

TH	---	TH+27H
TH+TA	---	TH+TA+27H
TH+2TA	---	TH+2TA+27H
---	---	---
TH+15TA	---	TH+15TA+27H

C) Set Graphic Home Address (GH)

This command defines the starting address of display RAM for the graphic display. The data in the Graphic home address(GH) is displayed at the home position of display(left end 8 bits in 1st line). When using the attribute function, the graphic

home address indicates the starting address of distribute RAM area.

D) Graphic Address Set (GA)

This command defines the number of columns by D1. The graphic area can be defined independently from the number of characters fixed by hardware setting of controller LSI. If the graphic area is defined as the actual number of columns on the LCD display, the address in graphic area can be continuous and the RAM can be used without ineffective areas. Note that the Graphic area will be different for depending on character font settings even if horizontal dot number is the same.

The relationship between display RAM address and display position(graphic display)

1) For 8X8 font: GA=1EH, 30X8=240 dots

GH	---	GH+1DH
GH+GA	---	GH+GA+1DH
GH+2GA	---	GH+2GA+1DH
---	---	---
GH+127GA	---	TH+127GA+1DH

8 bits data is as follows:

MSB							LSB
D7	D6	D5	D4	D3	D2	D1	D0

2) For 6X8 font: GA=28H, 40X6=240 dots

GH	---	GH+27H
GH+GA	---	GH+GA+27H
GH+2GA	---	GH+2GA+27H
---	---	---
TH+127GA	---	TH+127GA+27H

8 bits data is as follows:

MSB					LSB		
X	X	D5	D4	D3	D2	D1	D0

X: Invalid data

9.2.3 Mode Set

CODE	FUNCTION	OPERAND
1000X000	Logic "OR" of Graphic and Text Display	--
1000X001	Logic "EXOR" of Graphic and Text Display	--
1000X011	Logic "AND" of Graphic and Text Display	--
1000X100	Text Attribute Mode	--
10000XXX	CG ROM mode	--
10001XXX	CG RAM mode	--

X: Don't Care

Mode set command selects character generator (CGROM mode/CGRAM mode), and combination of text/graphic display. The display mode does not change until the next command is sent. The logical OR, EXOR, AND of text or graphic display can be displayed.

CG ROM mode: Built-in 128 characters CG ROM (code: 00H—7FH) and built-in CG RAM for 128 characters can be used (code: 80H—FFH).

CG RAM mode: built-in CG RAM for 256 characters (code: 00H—FFH) can be used. When CG ROM mode is selected, character code 00H—7FH is selected from built-in CG ROM and character code 80H-FFH is automatically selected from CG RAM.

Examples of the Logic operations:

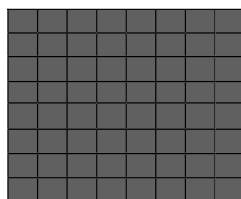

GRAPHIC

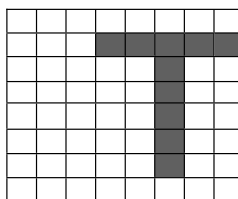

TEXT

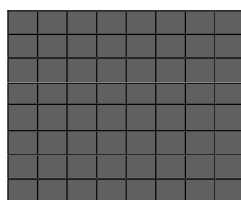

"OR"

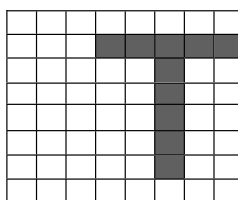

"AND"

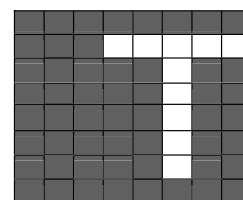

"EXOR"

(Note) Attribute functions can only be applied to text display, since the attribute data is placed in the graphic RAM area.

Attribute Functions:

Attribute operations are "Reverse display", "Character blink" and "Inhibit" in text display

mode. The attribute data is written in the graphic area defined by Set Control Word command (Graphic home address set and Graphic area set). Only text display is possible in Attribute Function mode, since the attribute data is stored in the graphic RAM area, graphic display is automatically disable. However, the Display Mode command must be used to turn both Text and Graphic on in order for the Attribute function to be available. The attribute data of the 1st character in "Text area" is written at the 1st byte in "graphic area", and attribute data of nth character is written at the nth byte in "Graphic area".

The attribute function is defined as follows:

Attribute RAM 1 byte

X	X	X	X	D3	D2	D1	D0
---	---	---	---	----	----	----	----

X: Don't care

D3	D2	D1	D0	FUNCTION
0	0	0	0	Normal display
0	1	0	1	Reverse display
0	0	1	1	Inhibit display
1	0	0	0	Blink of normal display
1	1	0	1	Blink of reverse display
1	0	1	1	Blink of inhibit display

9.2.4 Display Mode

CODE	FUNCTION	OPERAND
10010000	Display off	--
1001XX10	Cursor on, blink off	--
1001XX11	Cursor on, blink on	--
100101XX	Text on, graphic off	--
100110XX	Text off, graphic on	--
100111XX	Text on, graphic on	--

X: Don't Care

1	0	0	1	D3	D2	D1	D0
---	---	---	---	----	----	----	----

D0: Cursor blink D0=1: ON, D0=0: OFF
 D1: Cursor display D1=1: ON, D1=0: OFF
 D2: Text display D2=1: ON, D2=0: OFF
 D3: Graphic Display D3=1: ON, D3=0: OFF

(Note) It is necessary to turn on "Text display" and "Graphic display" in the following cases:

- a) Combination of text/graphic display
- b) Attribute function

9.2.5. Cursor Pattern Selection

CODE	FUNCTION	OPERAND
10100000	1-line cursor	--
10100001	2-line cursor	--
10100010	3-line cursor	--
10100011	4-line cursor	
10100100	5-line cursor	--
10100101	6-line cursor	--
10100110	7-line cursor	--
10100111	8-line cursor	

When cursor display is ON, this command selects the cursor pattern in range 1line to 8 lines. The cursor address is defined by the Set Cursor Pointer command.

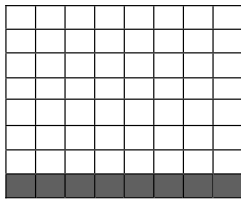

1-Line Cursor

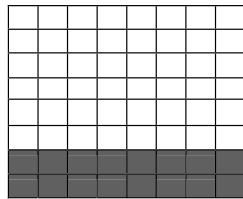

2-Line Cursor

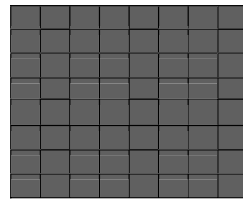

8-Line Cursor

9.2.6 Data Auto Read/Write

CODE	HEX	FUNCTION	OPERAND
10110000	B0H	Set data auto write	--
10110001	B1H	Set data auto read	--
10110010	B2H	Auto mode reset	--

This command is convenient to send full screen data, or receive full screen data from built-in display RAM. After setting auto mode, a Data Write(or Read) command is not need between each data. Data Auto Write(or Read) command should follow the Address Pointer Set command. After this command, the address pointer is automatically incremented by +1 after each data. After sending (or receiving) all data, Auto Mode Reset command is necessary to return normal operation because all data is regarded "display data" and no command can be accepted in the auto mode.

(Note) Status check for Auto mode(STA2 or STA3) should be checked between each data. Auto Reset should be performed after checking STA3=1(or STA2=1).

the followchart for Data Auto Read/Write

a) Auto Read Mode

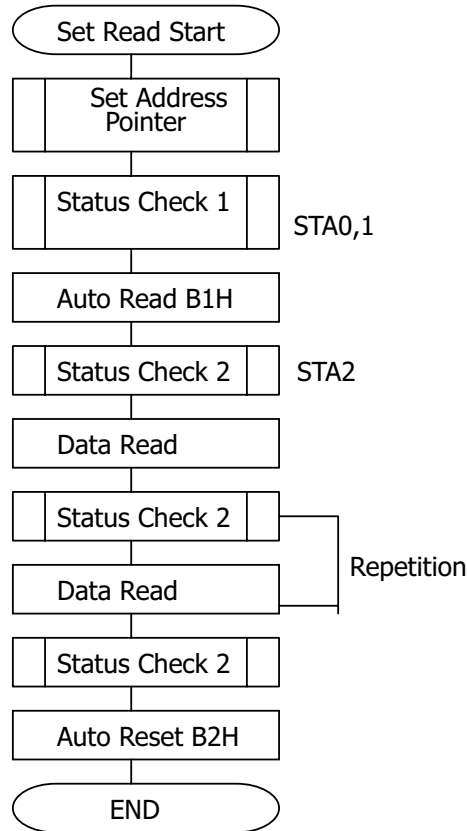

b) Auto Write Mode

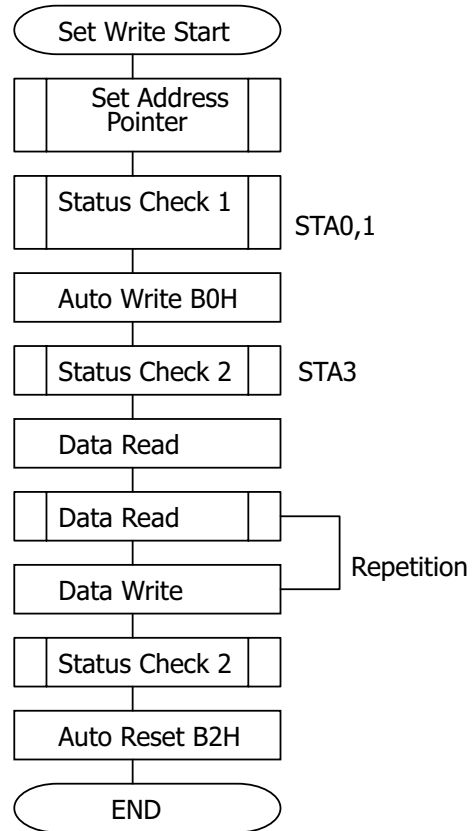

9.2.7 Data Read/Write

CODE	HEX	FUNCTION	OPERAND
11000000	C0H	Data write and increment ADP	Data
11000001	C1H	Data read and increment ADP	--
11000010	C2H	Data write and decrement ADP	Data
11000011	C3H	Data read and decrement ADP	--
11000100	C4H	Data write and nonvariable ADP	Data
11000101	C5H	Data read and nonvariable ADP	--

This command is used for writing data from MPU to display RAM, and reading data from display RAM to MPU. Data Write/Read should be executed after setting address by Set Address Pointer command. The address pointer can be automatically incremented or decremented by using this command.

(Note) This command is necessary for every 1 byte data.

The flowchart for Data Write

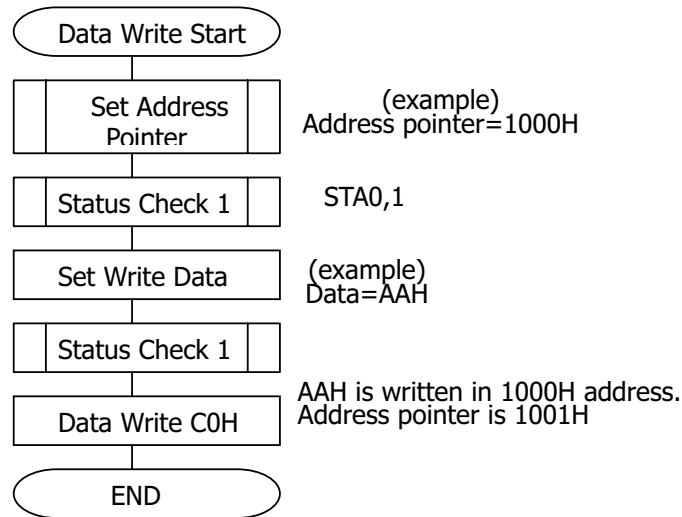

9.2.8 Screen Peek

CODE	HEX	FUNCTION	OPERAND
11100000	E0H	Screen Peek	--

This command is used to transfer 1 byte displayed data to data stack, and this 1 byte data can be read from MPU by data read command. So, logical combination data of text and graphic display on LCD screen can be read by this command. Status(STA6) should be checked just after Screen Peek command. If the address determined by Set Address Pointer command is not in graphic display RAM area, this command is ignored and status flag (STA6) is set.

The flowchart for Screen Peek command

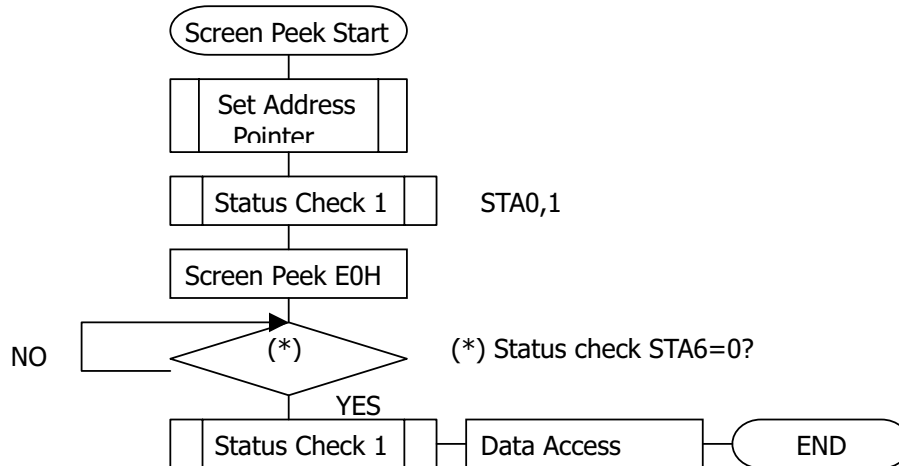

(Note) This command is available when hardware column number and software column number are the same. Software column number is related to Set Text Area and Set Graphic Area command. Set TA=28H, GA=28H when using this command.

9.2.9 Screen Copy

CODE	HEX	FUNCTION	OPERAND
11101000	E8H	Screen Copy	--

This command copies 1 row data displayed on LCD screen to the graphic RAM area specified by Set Address Pointer command. Start point of 1 row data on the screen is determined by the Set Address Pointer command. If attribute function is being used, this command is not available. Status (STA6) should be checked just after this command. If the address determined by Set Address Pointer command is not located in graphic RAM area, this command is ignored and status flag (STA6) is set.

The flowchart for Screen Copy command

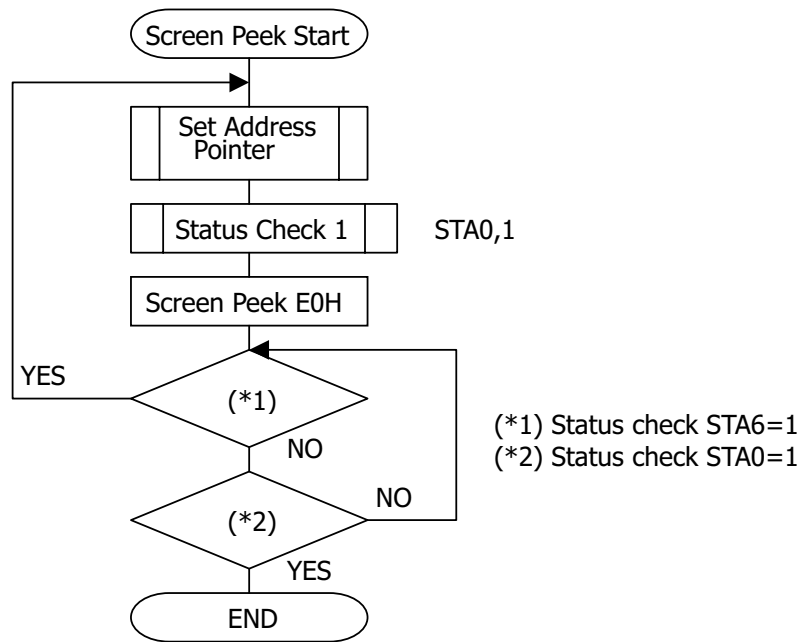

(Note) This command is available when hardware column number and software column number are the same. Software column number is related to Set Text Area and Set Graphic Area command. Set TA=28H, GA=28H when using this command.

9.2.10 Bit Set/Reset

CODE	FUNCTION	OPERAND
11110XXX	Bit Reset	--
11111XXX	Bit Set	--
1111X000	Bit 0 (LSB)	--
1111X001	Bit 1	
1111X010	Bit 2	--
1111X011	Bit 3	--
1111X100	Bit 4	--
1111X101	Bit 5	
1111X110	Bit 6	
1111X111	Bit 7 (MSB)	

X: Don't care

This command is used to set or reset a bit of the byte specified by the address pointer. Only one bit can be set/reset at one time.

The flowchart for Bit Set/Reset command

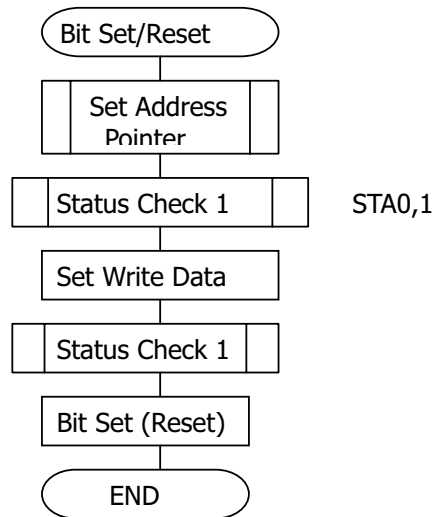

10 CHARACTER GENERATOR

10.1 Character Generator ROM

T6963C has a built-in 128-character Character Generator ROM.

The relationship between character codes and character patterns (CGROM type 0101)

LSB MSB	0	1	2	3	4	5	6	7	8	9	A	B	C	D	E	F
0		!	"	#	\$	%	&	'	()	*	+	,	-	.	/
1	0	1	2	3	4	5	6	7	8	9	:	;	<	=	>	?
2	a	b	c	d	e	f	g	h	i	j	k	l	m	n	o	
3	p	q	r	s	t	u	v	w	x	y	z	[\]	^	_
4	`	a	b	c	d	e	f	g	h	i	j	k	l	m	n	o
5	p	q	r	s	t	u	v	w	x	y	z	[\]	^	_
6	0	1	2	3	4	5	6	7	8	9	:	;	<	=	>	?
7	a	b	c	d	e	f	g	h	i	j	k	l	m	n	o	

10.2 Character Generator RAM

The character generator RAM is the built-in RAM which can be used as character generator after writing character pattern by program. While choosing "External CG RAM Mode", character codes 00H to FFH are assigned to CG RAM. While choosing "Internal CG ROM Mode", character codes 00H to 7FH are assigned to CG ROM and character codes 80H to FFH are assigned to CG RAM.

The offset register is used to determine the external character generator RAM area.

T6963C has a 16-bit address bus as follows:

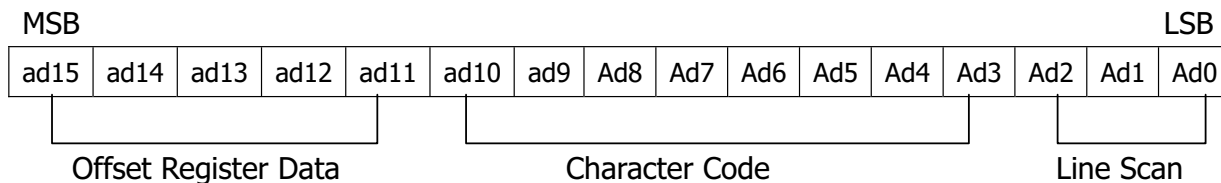

The upper 5 bits define the start address in external memory of CG RAM area. The next 8 bits define the character code of the character. The lower 3 bits define one of the

eight rows (8 dots each row) that define the character's shape.

The relationship between display RAM address and Offset Register

Offset Register Data	CG RAM HEX Address(Start to End)
00000	0000 TO 07FFH
00001	0800 TO 0FFFH
00010	1000 TO 17FFH
---	---
11100	E000 TO E7FFH
11101	E800 TO EFFFH
11110	F000 TO F7FFH
11111	F800 TO FFFFH

Example of making a character pattern in the CG RAM

Offset Register	02H
Character Code	80H
Character generator RAM start address	0001 0100 0000 0000
	1 4 0 0 H

	(address)	(data)
	1400H	00H
	1401H	1FH
	1402H	04H
	1403H	04H
	1404H	04H
	1405H	04H
	1406H	04H
	1407H	00H

11. INSPECTION STANDARDS

11.1 Inspection Conditions

The LCD shall be inspected under 40W white fluorescent light.

The distance between the eyes and the samples shall be more than 30cm.

All directions for inspecting the sample should be within 45 degree against perpendicular line.

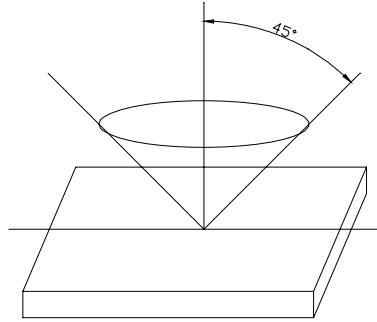

11.2 Definition of Applicable Zone

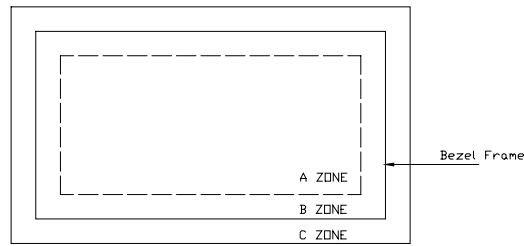

A Zone: Active Display Area

B Zone: Area from Bezel Frame to A Zone

C Zone: Rest Area of Bezel

A Zone + B Zone=Effective Viewing Area

11.3 Standards

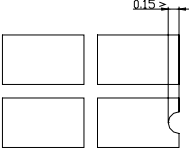
NO	PARAMETER	CRITERIA																																																										
1	Black and White Spots, Foreign Substances	<p>Round Shape</p> <table border="1" data-bbox="607 327 1360 590"> <thead> <tr> <th rowspan="2">Zone DIMENSION(MM)</th> <th colspan="3">Acceptable Number</th> </tr> <tr> <th>A</th> <th>B</th> <th>C</th> </tr> </thead> <tbody> <tr> <td>D≤0.1</td> <td>*</td> <td>*</td> <td>*</td> </tr> <tr> <td>0.1<D≤0.2</td> <td>5</td> <td>5</td> <td>*</td> </tr> <tr> <td>0.2<D≤0.3</td> <td>0</td> <td>1</td> <td>*</td> </tr> <tr> <td>0.3<D</td> <td>0</td> <td>0</td> <td>*</td> </tr> </tbody> </table> <p>D=(long+short)/2 * Disregard</p> <p>Line Shape</p> <table border="1" data-bbox="607 705 1360 1003"> <thead> <tr> <th colspan="2">Zone</th> <th colspan="3">Acceptable Number</th> </tr> <tr> <th>X(mm)</th> <th>Y(mm)</th> <th>A</th> <th>B</th> <th>C</th> </tr> </thead> <tbody> <tr> <td>-</td> <td>0.02≥W</td> <td>*</td> <td>*</td> <td>*</td> </tr> <tr> <td>2.0≥L</td> <td>0.03≥W</td> <td>3</td> <td>3</td> <td>*</td> </tr> <tr> <td>1.0≥L</td> <td>0.04≥W</td> <td>1</td> <td>2</td> <td>*</td> </tr> <tr> <td>1.0≥L</td> <td>0.05≥W</td> <td>0</td> <td>2</td> <td>*</td> </tr> <tr> <td>-</td> <td>0.05<W</td> <td colspan="3">Not acceptable</td> </tr> </tbody> </table> <p>X: Length Y: Width * Disregard Total defects shall not exceed 5.</p>	Zone DIMENSION(MM)	Acceptable Number			A	B	C	D≤0.1	*	*	*	0.1<D≤0.2	5	5	*	0.2<D≤0.3	0	1	*	0.3<D	0	0	*	Zone		Acceptable Number			X(mm)	Y(mm)	A	B	C	-	0.02≥W	*	*	*	2.0≥L	0.03≥W	3	3	*	1.0≥L	0.04≥W	1	2	*	1.0≥L	0.05≥W	0	2	*	-	0.05<W	Not acceptable		
Zone DIMENSION(MM)	Acceptable Number																																																											
	A	B	C																																																									
D≤0.1	*	*	*																																																									
0.1<D≤0.2	5	5	*																																																									
0.2<D≤0.3	0	1	*																																																									
0.3<D	0	0	*																																																									
Zone		Acceptable Number																																																										
X(mm)	Y(mm)	A	B	C																																																								
-	0.02≥W	*	*	*																																																								
2.0≥L	0.03≥W	3	3	*																																																								
1.0≥L	0.04≥W	1	2	*																																																								
1.0≥L	0.05≥W	0	2	*																																																								
-	0.05<W	Not acceptable																																																										
2	Air Bubbles (Between glass and polarizer)	<table border="1" data-bbox="607 1125 1360 1360"> <thead> <tr> <th rowspan="2">Zone Dimension(mm)</th> <th colspan="3">Acceptable Number</th> </tr> <tr> <th>A</th> <th>B</th> <th>C</th> </tr> </thead> <tbody> <tr> <td>D≤0.1</td> <td>*</td> <td>*</td> <td>*</td> </tr> <tr> <td>0.1<D≤0.2</td> <td>5</td> <td>5</td> <td>*</td> </tr> <tr> <td>0.2<D≤0.3</td> <td>0</td> <td>1</td> <td>*</td> </tr> <tr> <td>0.3<D</td> <td>0</td> <td>0</td> <td>*</td> </tr> </tbody> </table> <p>*: Disregard Total defects shall not exceed 3.</p>	Zone Dimension(mm)	Acceptable Number			A	B	C	D≤0.1	*	*	*	0.1<D≤0.2	5	5	*	0.2<D≤0.3	0	1	*	0.3<D	0	0	*																																			
Zone Dimension(mm)	Acceptable Number																																																											
	A	B	C																																																									
D≤0.1	*	*	*																																																									
0.1<D≤0.2	5	5	*																																																									
0.2<D≤0.3	0	1	*																																																									
0.3<D	0	0	*																																																									
3	The Shape of Dot	<p>(1) Dot Shape(with dent)</p>  <p>As per the sketch of left hand.</p> <p>(2) Dot Shape(with Projection)</p>																																																										

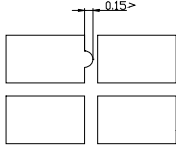
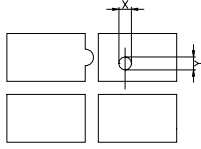
		 <p>Should not connect to next dot.</p> <p>(3) Pin Hole</p>
		 <p>$(X+Y)/2 < 0.2\text{mm}$ (less than 0.1mm is not counted)</p> <p>Total defects shall not exceed 5.</p>
4	Polarizer Scratches	Not to be conspicuous defects.
5	Polarizer Dirts	If the stains are removed easily from LCD surface, the module is not defective.
6	Color Variation	Not to be conspicuous defects.